

BDR190CSS

34.5" x 35.5" x 21.75" (H x W x D)

Complete stainless steel two-drawer refrigerator with towel bar handles, for built-in or free-standing use

Highlights:

- Automatic defrost operation saves maintenance
- Stainless steel look is both professional and elegant
- Two slide drawers open and close smoothly
- Includes metal containers for creative storage options



Built-in installation	Make the best use of space by installing your refrigerator under the counter and flush with other cabinets
Automatic defrost	Simplify appliance care by letting your refrigerator defrost itself
Complete stainless steel body	Transform your kitchen with the refinement of stainless steel
See-thru glass bottom top drawer	Save time rummaging through refrigerator contents with this unique and practical "window" into your bottom drawer from the top
Adjustable thermostat	Control your food's temperature with ease and accuracy
Metal containers	Organize your refrigerator contents with these attractive and convenient storage bins
Lift-out containers with covers	Get the most out of your storage space by separating your items
Interior light	Automatically illuminates when you open the door
Slide-out drawers	Smooth gliding drawers open easily with generous space to reach inside
Professional towel bar handles	Add a touch of luxury with sturdy but stylish 12" door handles in stainless steel

Specifications:

Height	34.5 up to 34.5"
Width	35.5"
Depth	21.75"
Capacity	6.7 cu.ft.
Ext Depth with Handle	24.25"
Interior Height 1	24.0"
Interior Width 1	31.5"
Interior Depth 1	17.5"
Comp Step Height	4.0"
Comp Step Width	19.0"
Comp Step Depth	5.5"
Height Adjustable	true
Shipping Weight	252.0 lbs.
US Electrical Safety	UL
Reversible	Factory Reversible
Drawers	true
Drawer Quantity	2
Defrost Type	Automatic
Depth with door at 90°	39.0"
Thermostat Type	Dial
Light	true
Condensor Location	Rear of Unit
Fan Type	Exterior
Freon Type	R134a
Level Legs Quantity	4
Freon Oz	2.3
Parts/Labor Warranty	1 Year
Compressor Warranty	5 Years

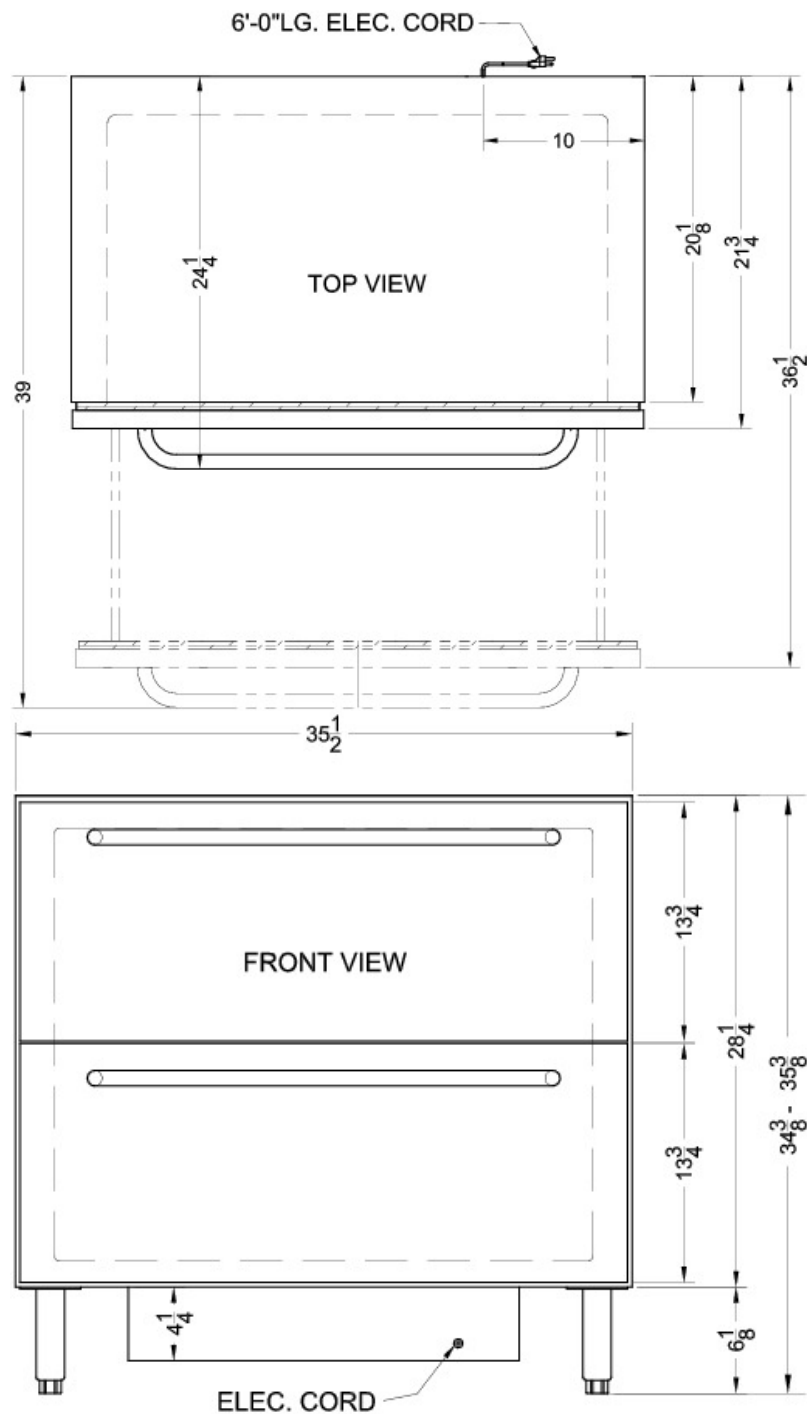

Summit Appliance Division, Felix Storch, Inc.
 770 Garrison Ave • Bronx, NY 10474
 Phone: 718-893-3900 • Fax: 718-842-3093
 Email: info@summitappliance.com