



30" Gas Cooktop

The patented dual-stacked burner design of Wolf gas cooktops uses its upper-level burner for maximum heat transfer. Merely turn down the knob and the lower-tier burners delivers fine-tuning control and true simmer. The sealed burners and deep recess of the seamless drawn pan make clean up a snap. Wolf gas cooktops are available in natural or LP gas.



FEATURES

- Stainless steel top construction.
- Four dual-stacked, sealed burners with automatic reignition on all settings.
- One large 15,000 Btu sealed burner with 950 Btu delivered at simmer.
- One medium 12,000 Btu sealed burner with 950 Btu delivered at simmer.
- Two small 9,200 Btu sealed burners with 300 Btu delivered at simmer.
- Individual spark ignition system.
- True simmer setting on all burners.
- Illuminated control panel with two-tiered control knobs.
- Low-profile cast iron continuous burner grates with matte porcelain finish.
- Seamless drawn burner pan.

ACCESSORIES

- Filler strip for installation of multiple cooktops or modules.
- One-piece wok grate and single burner grate.

Accessories are available through your authorized Wolf dealer. For local dealer information, visit the find a showroom section of our website, wolfappliance.com.



Model CT30G/S



This appliance is certified by Star-K to meet strict religious regulations in conjunction with specific instructions found on www.star-k.org.

DUAL-STACKED BURNERS



Melt setting.



Full-flame setting.



30" Gas Cooktop

OVERALL DIMENSIONS

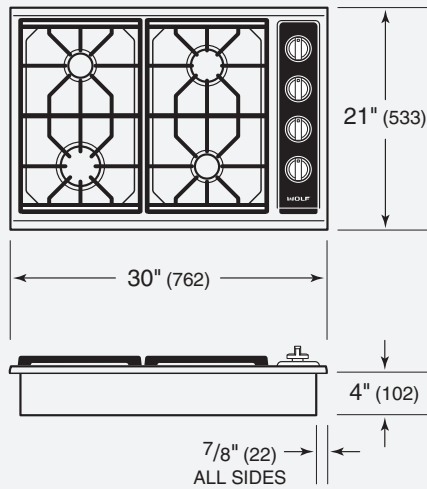

Unit dimensions may vary by $\pm 1/8$ ".

SPECIFICATIONS

Overall Width	30"
Overall Height	4"
Overall Depth	21"
Burner Rating	
(1) 15,000 Btu with 950 Btu delivered at simmer	
(1) 12,000 Btu with 950 Btu delivered at simmer	
(2) 9,200 Btu with 300 Btu delivered at simmer	
Countertop Cut-Out Width	29"
Countertop Cut-Out Depth	19 1/4"
Electrical Requirements	120 V AC, 60 Hz 15 amp circuit
Power Cord	6' cord with grounded plug
Gas Rating	45,400 Btu
Shipping Weight	50 lbs

INSTALLATION SPECIFICATIONS

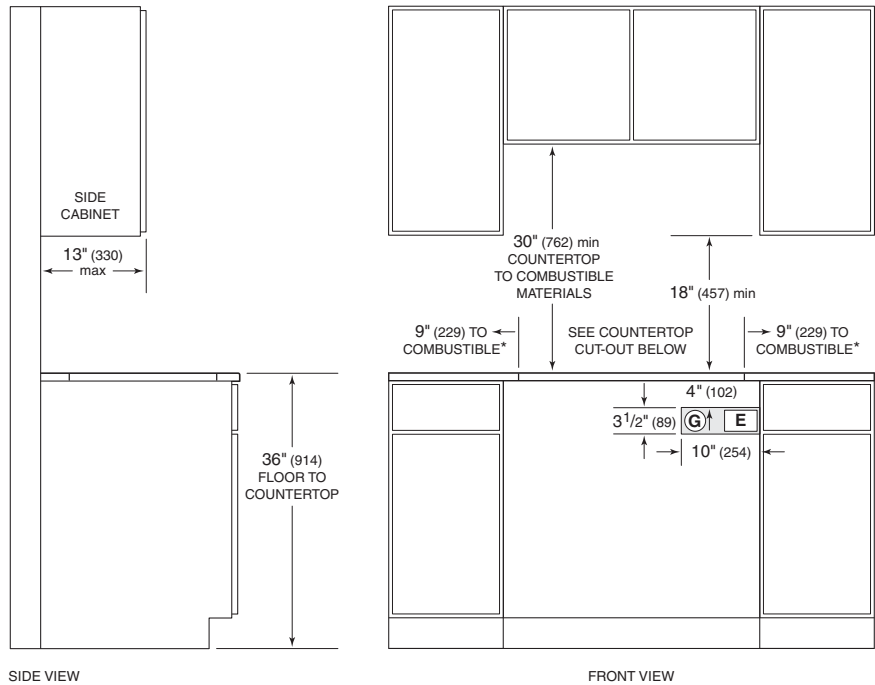

*Minimum clearance from cooktop cut-out to combustible materials up to 18" (457) above countertop.

NOTE: Gas and electrical location applies only to installation with built-in oven.

INSTALLATION NOTES

A Wolf 30" built-in single oven may be installed below the 30" gas cooktop. Refer to specifications for built-in ovens.

For LP gas installations above 8,600' a high altitude conversion kit is required. For natural gas installations above 10,250', contact your authorized Wolf dealer.

Complete installation specifications can be found on our website, wolfappliance.com.

Countertop Cut-Out Dimensions

Dimensions in parentheses are in millimeters unless otherwise specified.

