

AMERICAN RANGE

PROFESSIONAL QUALITY COOKING EQUIPMENT

CUISINE SERIES

30" Range with Five Sealed Gas Burners



ARR-530

(shown with optional island back and leg caps)

DESIGN



CLASS



FUNCTION

DESIGNED & BUILT IN USA
PROFESSIONAL COOKING EQUIPMENT

30" RESIDENTIAL GAS RANGE

RANGE TOP FEATURES

- Sealed burners deliver exceptional performance at every level setting and lift off to provide easy cleanup
- 3 sizes of burners to serve your everyday needs: 17,000 BTU (lg), 13,000 BTU (med), 9,000 BTU (sm)
- Variable infinite flame settings for all sealed top burners
- Fail-safe system ensures re-ignition in the event the flame goes out even on the lowest burner setting
- Continuous and flush commercial-grade cast iron grates allow for easy transfer of pots and pans across the entire cooking surface
- Sealed Single Piece tooled porcelainized cook top can hold more than a gallon of spills
- Analog controls provide easy, push and turn operation ensuring child safety
- Blue LED light indicates oven functions
- Heavy metal die-cast black satin knobs with chrome bezels
- Stainless Steel Island Back Trim is included and installed

OVEN FEATURES

- Multiple functions include: Standard Bake, Innovention® Convection Bake, Infrared Broil and Fan mode
- Innovention® System with convection fan optimizes uniform air flow
- Two chrome racks glide at 5 (including base) cooking levels on heavy chrome side supports
- Accommodates full size commercial sheet pan
- Front panel switch controls oven lighting for optimal visibility
- Oven front construction is a durable, precision-made one piece frame

INNOVECTION® CONVECTION OVEN TECHNOLOGY

Balanced turbulent heat distribution is essential when baking, roasting, and dehydrating food. The American Range Innovention® convection oven technology features dual convection motors and louvered side panels to enhance uniform heat distribution throughout the large oven cavity. The strategic placement of the dual Innovention® convection fans ensures consistent heat distribution even when challenged with cooking the largest turkey, ham or roast.



INNOVECTION® CONVECTION OVEN IS GREEN TECHNOLOGY

The highly efficient design of the Innovention® Convection Oven uses 19% less gas versus a standard convection oven.

TECHNICAL SPECIFICATIONS

Overall Oven Capacity	4.3 CU. FT.
Oven Dimensions	26" W x 19" D x 15" H
Surface Burner Rating	17,000 BTU (lg) - 13,000 BTU (md) - 9,000 BTU (sm)
Infrared Broiler	17,000 BTU (each oven)
Oven Bake Burner	28,000 BTU (each oven)
Total Gas Connection Rating	ARR-530 102,000 BTU 5 burners
Gas Supply	7" W.C. Natural, 11" W.C. Propane
Electrical Supply	120 VAC 15 AMP 60 Hz Single Phase
Shipping Weight	330.5 Lbs

COLOR KNOBS

red knobs fits: ARR-530	KSR-GF530
burgundy knobs fits: ARR-530	KSB-GF530

ACCESSORIES & OPTIONS

Island Back (standard)	ARR-30SIB-C	20" High Back w/ Shelf	ARR-3021HBS-C	Set of 2 Casters	ARR-2CAS-C	Porcelainized Broiler Pan	R31005
Island Back (welded)	ARR-30IB-C	S/S Curb Base	ARR-30CB-C	12" Cutting Board	ARR-CUTB-12-C	Wok Adapter	ARR-WOK-C
4" Stub Back	ARR-304SB-C	S/S Leg Caps (2)	ARR-2LC-C	12" Griddle Plate	ARR-PGPI2-C		

CUSTOMIZE YOUR RANGE: Now you can customize your American Range to match your kitchen setting. Pick from numerous colors and finishes to give your range a unique one-of-a-kind look. For more details regarding color and finish options, go to our website: www.americanrange.com.



DESIGNER COLORS



DESIGNER FINISHES



N = Natural gas Must ship from factory with proper gas type.
L = LP Gas Must provide **N** or **L** after model number for type of gas needed.
Example: ARR-304
 Must specify elevation if over 1000 ft. when ordering.

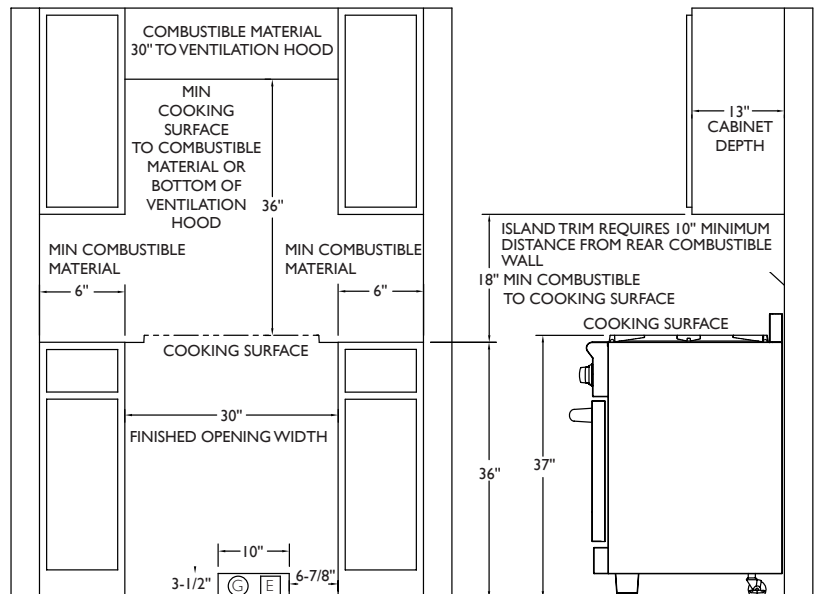
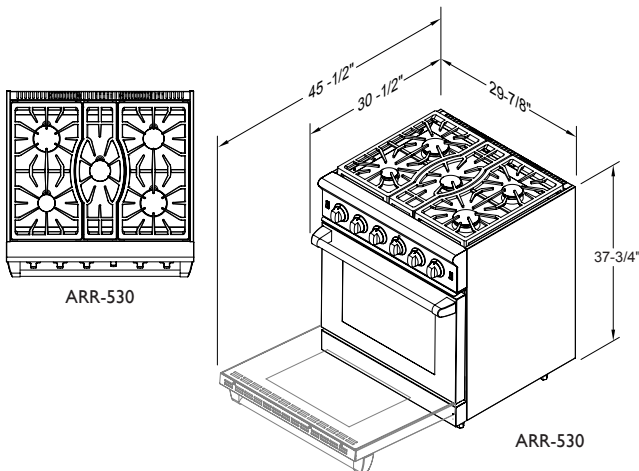

ISLAND OR PENINSULA INSTALLATIONS 10" MINIMUM CLEARANCE FROM BACK OF RANGE TO COMBUSTIBLE SURFACE ISLAND TRIM IS 0". CLEARANCE TO NON COMBUSTIBLE SURFACE NO SIDE WALL ABOVE COOKING SURFACE (G) (E) LOCATION OF GAS AND ELECTRICAL SUPPLY