



Buy it for looks. Buy it for life.®

# Specifications

## SINK DESCRIPTION

- Manufactured of 22 gauge, type 301 nickel-bearing stainless steel
- The large bowl is a minimum of 21-1/4" wide by 16" and is 7-1/4" deep
- The sink ledge has four fixture mounting holes, 1-1/2" in diameter and 4" on center
- Has one 3-1/2" diameter recessed drain opening
- Is fully undercoated with a sound and temperature insulating material
- The exposed surfaces are polished to a lustrous satin tone finish
- Includes all necessary mounting hardware

## CUT OUT DIMENSIONS

- Cut out dimensions are 24-3/8" x 21-3/8", with a 1-1/2" corner radius. A tolerance of plus or minus 1/16" is acceptable

## WARRANTY

- Warranted for five years against material or manufacturing defects

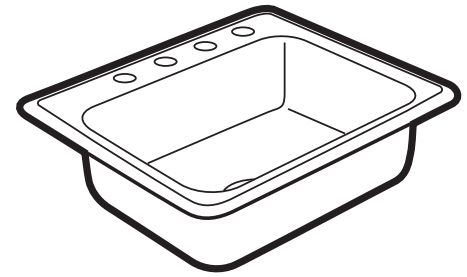

**Excalibur®**  
**Single Bowl Kitchen Sink**  
**Model: 22889**  
 (ED-2522-4-7.25)

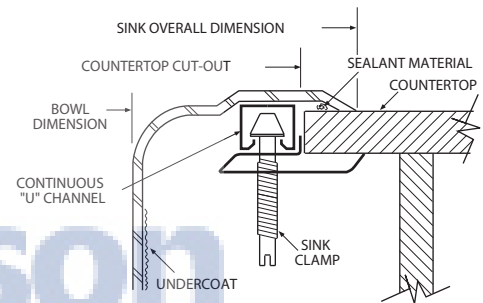

**Installation Detail**

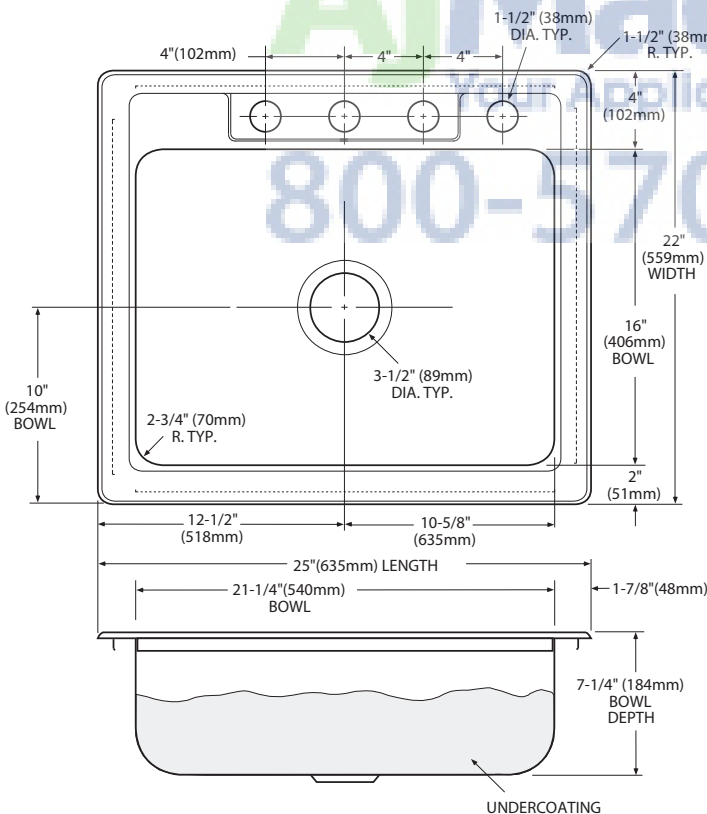

## CRITICAL DIMENSIONS

(DO NOT SCALE)

FOR MORE INFORMATION CALL: 1-800-BUY-MOEN

www.moen.com