



# Whirlpool® Side by Side Refrigerator

## PRODUCT MODEL NUMBERS

ED2LHAXM	GD5NHAXM
ED2NHAXN	GD5PHAXM
ED2SHAXM	GD5RHAXN
ED5LHAXM	GD5SHAXN
ED5NHAXN	GD5YHAXN
ED5RHAXN	GS2SHAXN
ED5SHAXM	GS2SHEXN
ED5SHAXN	GS5SHAXN
ED5THAXM	GS6SHEXN
GD2NHAXM	
GD2SHAXN	

**Electrical:** A 115 Volt, 60 Hz., AC only 15 or 20 amp fused, grounded electrical supply is required. It is recommended that a separate circuit serving only your refrigerator be provided. Use an outlet that cannot be turned off by a switch. Do not use an extension cord.

**Water:** A cold water line with water pressure between 30 and 120 psi is required for the water dispenser and ice maker. If a reverse osmosis water filtration system is connected to your cold water supply, the water pressure to the reverse osmosis system needs to be a minimum of 40 to 60 psi (276-414 kPa).

## OVERALL DIMENSIONS

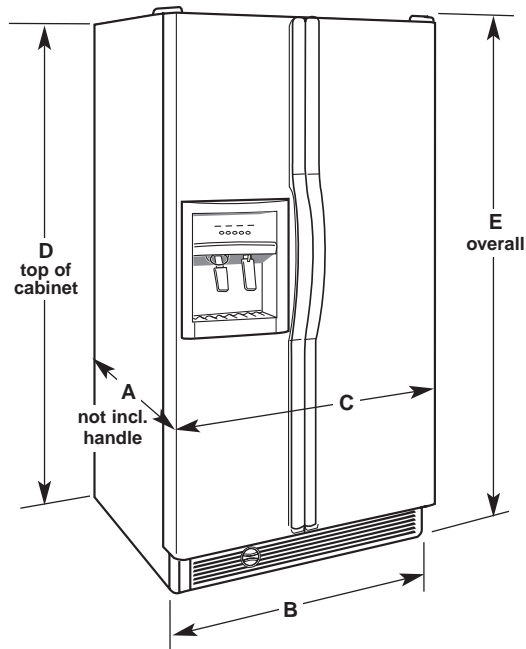

Model size	Depth "A"	Cab. Width "B"	Door Width "C"	Cab. Height "D"	Overall Height "E"
<b>STANDARD MODELS</b>					
22 cu.ft.	31 3/8"	32 3/4"	33 1/8"	65 7/8"	66 3/4"
25 cu.ft.	31 3/8"	35 1/2"	35 7/8"	68 7/8"	69 3/4"
<b>CURVED DOOR MODELS</b>					
22 cu.ft.	33 1/4"	32 3/4"	33 1/2"	65 7/8"	67 1/4"
25 cu.ft.	33 1/4"	35 1/2"	36 1/8"	68 7/8"	70 1/4"
26 cu.ft.	33 1/4"	35 1/2"	36 1/8"	68 7/8"	70 1/4"
<b>TRIM KIT (attached) MODELS</b>					
25 cu.ft.	31 1/4"	35 1/2"	35 15/16"	68 3/8"	70"

## LOCATION REQUIREMENTS

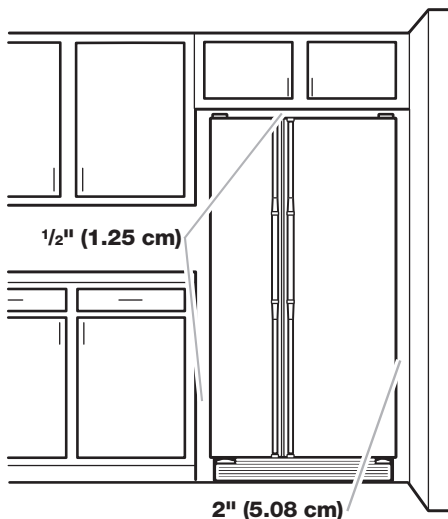

To ensure proper ventilation for your refrigerator, allow for 1/2 in. (1.25 cm) space on each side and at the top. (At the top, when using half depth cabinet, use top of cabinet height "D" dimension. When using full depth cabinet, use overall "E" dimension.) When installing your refrigerator next to a fixed wall, leave 2 in. (5.08 cm) minimum on each side (depending on your model) to allow for the door to swing open. If your refrigerator has a water dispenser and ice maker, allow extra space at the back for the water line connections.

**NOTE:** Do not install the refrigerator near an oven, radiator, or other heat source, nor in a location where the temperature will fall below 55°F (13°C).