

GLADIATOR™ Freezerator™ Convertible Refrigerator/Freezer

PRODUCT MODEL NUMBERS

GARF19XXPK

Electrical: A 115 Volt, 60 Hz., AC only 15- or 20-amp fused, grounded electrical supply is required. It is recommended that a separate circuit serving only your convertible refrigerator/freezer be provided. Use an outlet that cannot be turned off by a switch. Do not use an extension cord.

OVERALL DIMENSIONS

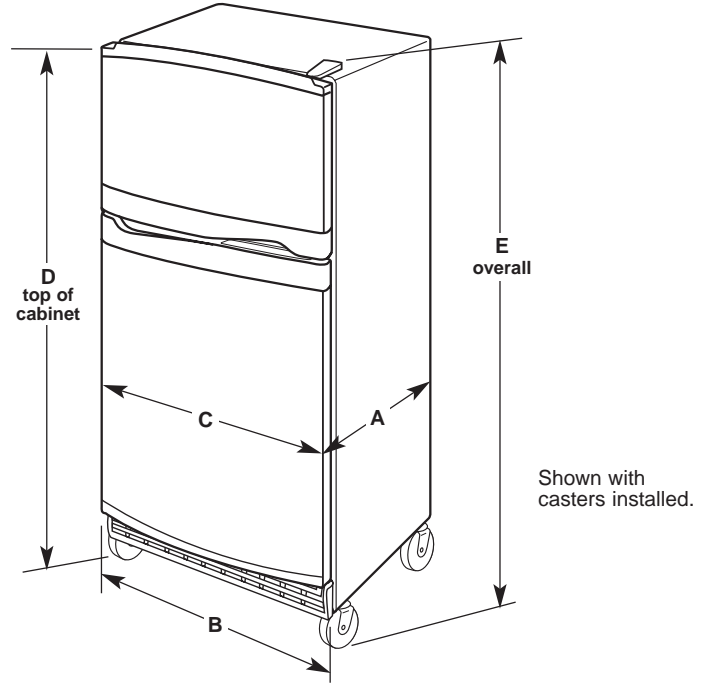

Model size	Depth "A"	Cab. Width "B"	Door Width "C"	Cab. Height "D"		Overall Height "E"	
				rollers	w/casters	rollers	w/casters
19 cu.ft.	31 1/2"	29 1/2"	30 1/8"	65 1/2"	72 1/8"	66 1/2"	73 1/8"

LOCATION REQUIREMENTS

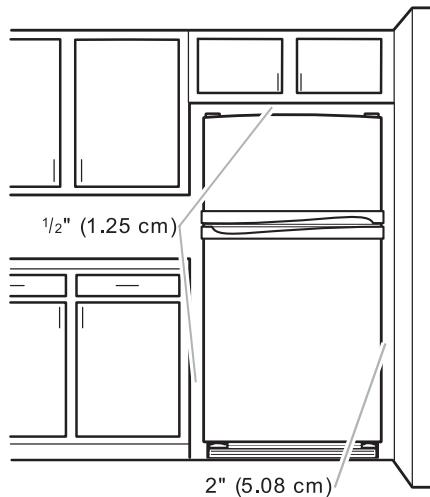

To ensure proper ventilation for your convertible refrigerator/freezer, allow for 1/2" (1.25 cm) space on each side and at the top. When installing your convertible refrigerator/freezer next to a fixed wall, leave 2" (5.08 cm) minimum clearance on each side to allow for the door to swing open.

NOTE: Do not install the convertible refrigerator/freezer near an oven, radiator, or other heat source where temperature will rise above 110°F (43°C), nor in a location where the temperature will fall below 0°F (-17°C).