

## Model 2075WC WINE CAPTAIN®

WINE CAPTAIN® wine storage unit with 48 bottle capacity.

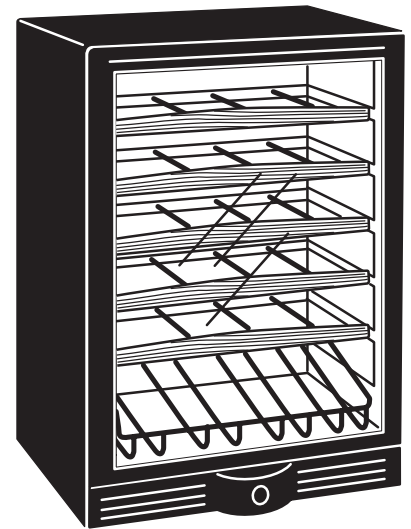
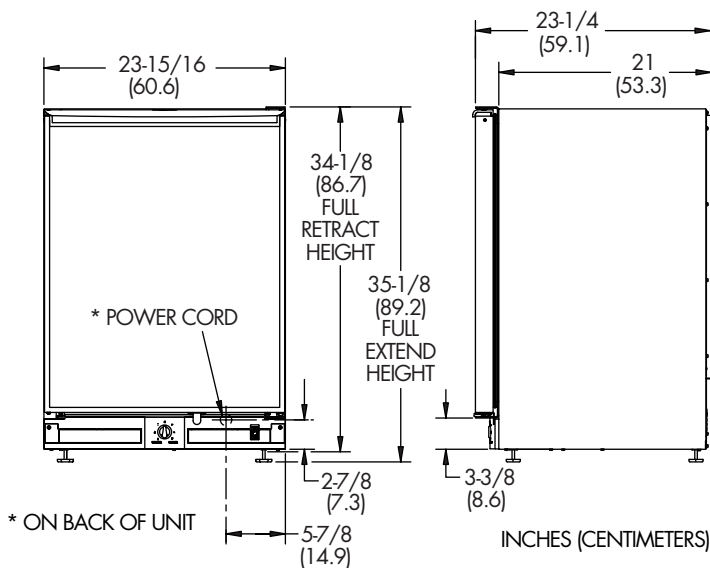

## SUPERIOR FEATURES OF ÉCHELON™

- Three temperature zones within one cabinet**  
**BENEFIT:** Ensures that the specific type of wine is maintained at the proper temperature. Sparkling wines such as champagnes are stored at the bottom and maintain a product temperature of approximately 45° F (7° C). White wines are stored in the middle section of the cabinet and maintain a product temperature of 50-55° F (10-12° C). Red wines are stored at the top of the cabinet and maintain a product temperature of approximately 60° F (15° C).
- Five sturdy, slide out, fully extendable wine racks**  
**BENEFIT:** Easy access to all wine bottles especially those located on the rear portion of the rack. Bottles are stored in a horizontal position keeping the cork moist to prevent air from entering the bottle.
- Seamless door frame for black and white units**  
**BENEFIT:** The 1-1/2 inch wide door frame is seamless therefore it contains no miter cuts in the corners eliminating the "picture frame" look and providing a much cleaner and sleeker appearance.
- All stainless steel 2075WC units have a wrapped 2 inch wide stainless steel door frame with sculpted, contoured handle.**  
**BENEFIT:** A one piece stainless steel door frame with a sculpted, contoured handle distinguishes the Échelon™ 2075WC stainless steel unit from heavier "commercial" looks. All stainless steel Wine Captain® units have a tinted thermal glass door, a full wrap stainless cabinet, stainless hinges, and black grille. All stainless units must be ordered either right or left hand hinged and are not field reversible.
- Black vinyl wine racks**  
**BENEFIT:** The black vinyl blends well with the wine bottles therefore placing greater visual emphasis on the wine itself. The vinyl coating on the racks also "grip" the wine bottles more securely.

# SUPERIOR FEATURES OF ÉCHELON™

---

6. **The wine racks have a contoured, wooden front facing**  
**BENEFIT:** The contoured front facing adds an upscale appearance to the 2075WC. The wood is maple and is treated for durability and for use in a temperature controlled environment. The wood facing may be stained or replaced in its entirety by the end user with other wood products or such products as Corian®, Sandstone or other like products.
7. **Bottom fixed "Wine Display Rack" - EXCLUSIVE U-LINE feature**  
**BENEFIT:** Displays wine bottles at an approximate 40 degree angle. The "Display Rack" holds eight bottles clearly displaying the labels of four bottles.
8. **Tinted, thermal glass door**  
**BENEFIT:** Protects your wines from potentially harmful light rays.
9. **Field reversible doors (except stainless steel).**  
**BENEFIT:** Greater flexibility where the unit can be installed and allows for side-by-side applications.
10. **Forty-eight (48) bottle capacity**  
**BENEFIT:** Generous wine storage capacity.
11. **Interior light which can remain either "off" or "on" when the door is closed. The interior light will automatically illuminate when the door is opened.**  
**BENEFIT:** For those special occasions when you invite guests to dine, you may attractively "display" your wine collection with the door closed.
12. **Self closing door hinges are engaged when door is open approximately 8-10 inches**  
**BENEFIT:** Ensures a positive door seal and prevents door bounce back.
13. **"L" shaped door hinges**  
**BENEFIT:** This hinge design provides greater door support.
14. **A slightly contoured, across the top, integrated door handle design for black and white models**  
**BENEFIT:** The contoured shape maintains the stylized shape of the Échelon™ series plus permits full door field reversibility on black and white units.
15. **Flat, recessed, front grille with "warmer/colder" control settings**  
**BENEFIT:** Adjustable temperature control. Greater toe kick space. Easy to read molded temperature control settings. The grille shields the interior motor compartment and all electrical components from view.

---

## ADDITIONAL FEATURES

1. Vinyl clad steel cabinet (black/white)
2. Adjustable leveling legs
3. Available in black, white and stainless steel

---

## BENEFITS

- Textured, rich look. Resistant to scratching, peeling and flaking.
- More precise under the counter fit, durable – factory installed.
- Blends with all cabinet colors.