



Échelon™

Model 2075R

Custom 1/4" Door Panel: 28-5/32" H x 23-1/32" W (71.5 cm x 58.5 cm)
3/4" Full Overlay Panel: 29-7/8" H x 23-3/4" W (75.9 cm x 60.3 cm)

See Overlay Door Panel Preparation Instructions

5.7 cubic foot built-in under the counter (or freestanding) refrigerator

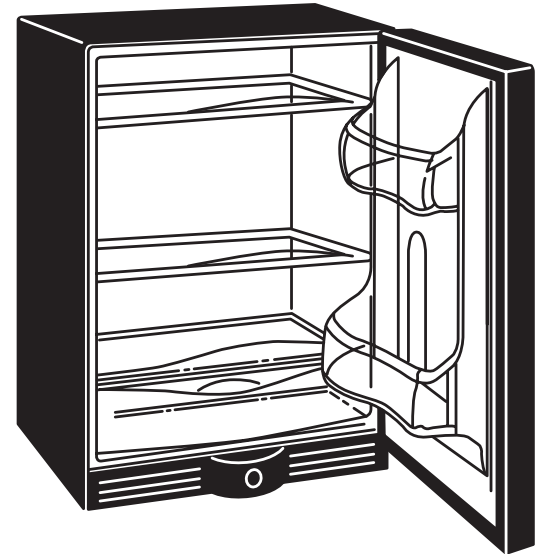
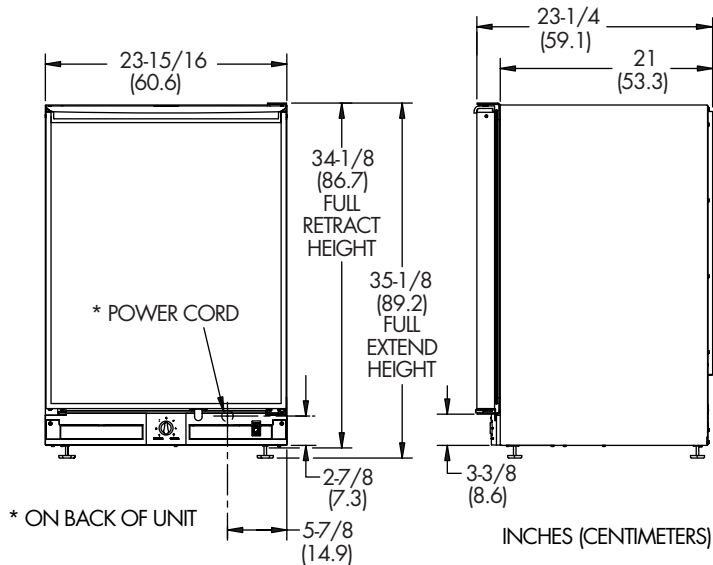

EXCLUSIVE FEATURES OF ÉCHELON™

- 1. Optional full overlay door capability (panel kit) using a 3/4 inch thick panel**
BENEFIT: Provides a fully integrated appearance with surrounding cabinets. Overlay panel is easily attached to the door.
- 2. Three fully encapsulated, contoured, spill proof shelves that are adjustable**
BENEFIT: Upscale appearance that contains spills to one shelf. Easy to clean. Stylized, etched bottom crisper shelf.
- 3. Two adjustable, contoured, self contained, inner door "pick-off" shelves**
BENEFIT: These highly stylized shelves are adjustable for the storage of a variety of different bottle, can, and container sizes and shapes thereby providing optimum space utilization and flexibility. The self contained shelves can be removed and used to transport their contents to other cooking areas in the home or outside patio.
- 4. Bottom inner door shelf accommodates a two liter or 750 ml. bottle**
BENEFIT: Provides greater storage capabilities and flexibility.
- 5. Highly styled, removable, clear lower crisper drawer**
BENEFIT: Optimizes the organization of product stored in the crisper. The crisper may also be used to transport its contents to a cooking or serving area.
- 6. Indented or recessed shelf channels support the encapsulated shelves**
BENEFIT: Provides a sleek, clean appearance to the interior of the cabinet by eliminating protruding shelf supports. Also provides a more secure, rigid fit for the encapsulated shelves.



SUPERIOR FEATURES OF ÉCHELON™

- 1. Self closing door hinges are engaged when door is open approximately 8-10 inches**
BENEFIT: Ensures a positive door seal and prevents door bounce back.
- 2. "L" shaped door hinges**
BENEFIT: This hinge design provides greater door support thereby permitting larger and heavier door panels and full overlay doors to be utilized.
- 3. A slightly contoured, across the top, integrated door handle design for black and white models**
BENEFIT: The contoured shape maintains the stylized shape of the Échelon™ series plus permits full door field reversibility on black and white units.
- 4. Flat, recessed, front grille with "warmer/colder" control settings**
BENEFIT: Greater toe kick space. Easy to read molded temperature control settings. The grille design shields the interior motor compartment and all electrical components from view.
- 5. New condenser design**
BENEFIT: Optimizes product performance and energy efficiency while providing further reductions in noise levels.
- 6. All stainless steel units have a seamless full wrap stainless steel cabinet and door with sculpted, contoured handle.**
BENEFIT: This seamless full wrap stainless steel door with sculpted stainless handle distinguishes the Echelon™ stainless steel units from other heavier "commercial" looks. All stainless steel units have a full wrap stainless cabinet, stainless hinges, and black grille. All stainless units must be ordered either right or left hand hinged and are not field reversible.
- 7. The 2075R stainless unit is deemed suitable for outdoor use by UL.**
BENEFIT: For those outdoor applications that require products that are deemed suitable for outdoor use by UL, the 2075R stainless steel unit meets these requirements.
- 8. New evaporator design**
BENEFIT: Provides for more uniform temperatures throughout the interior cabinet, ensuring that products are stored at the desired temperature.
- 9. Field reversible doors (except stainless steel).**
BENEFIT: Greater flexibility where the unit can be installed and allows for side-by-side applications.

ADDITIONAL FEATURES

1. Automatic (cycle) Defrost
2. Built-in or freestanding
3. All doors (except stainless steel models) accommodate a 1/4 inch thick custom panel. Door comes standard with a factory installed flush panel.
4. Door locks optional on black and white units. Not available on stainless steel.
5. Adjustable temperature control
6. Interior light.
7. Vinyl clad steel cabinet (black/white)
8. Adjustable leveling legs.
9. Available in black, white, stainless steel.
10. Energy Star Appliance.

BENEFITS

- Maintenance free defrosting
- Provides custom look. No additional clearance around sides, top, or rear for ventilation. **Do not obstruct front grille.**
- Standard feature to achieve a custom, built-in look by matching surrounding cabinets.
- Doors remain field reversible. Locks located in upper middle portion of the door.
- Ability to adjust temperature.
- Automatically illuminates when door opens.
- Textured rich look. More resistant to scratching, peeling, flaking. Cabinet sides extend to the floor.
- More precise under the counter fit, durable – factory installed.
- Blends with all cabinet colors.
- Qualifies for U.S. Government ENERGY STAR program.