

### FEATURED MODEL

**157-073P-CR** BLANCOMERKUR PLUS™ Kitchen Faucet  
in Chrome

### ADDITIONAL MODELS

**157-073P-ST** Stainless (Satin Nickel)

### FEATURES

- Solid brass body
- Ceramic disc cartridge
- Reversible mounting hardware adapts to thick or thin mounting surfaces
- 2.2 G.P.M. flow rate
- Installation in a 1-3/8" hole
- Double spiral flexible pull-out spray hose

### CODE/STANDARDS COMPLIANCE

ASME A112.18.1-2005

IAPMO Listed

### WARRANTY

Blanco America's Kitchen faucets feature a "NO HASSLE" LIMITED LIFETIME WARRANTY to be free of all manufacturing defects under normal use. See our complete warranty for details.

While Blanco America endeavors to provide accurate information, all dimensions are nominal, cannot be guaranteed, and are subject to change or cancellation. Blanco America assumes no responsibility for use of superseded or voided specifications.

### PRODUCT SPECIFICATION

Kitchen faucet to include solid brass body, added height, full-handle design and pull-out spray. Faucet dimensions to be as follows: Reach: 9-3/4"; Spout Height: 6-1/4". Reversible mounting hardware to adapt to thick or thin mounting surfaces. Kitchen faucet to be BLANCOMERKUR PLUS™, Model 157-073P-\_\_\_\_\_in\_\_\_\_\_finish.

- Polished Chrome 157-073P-CR
- Stainless (Satin Nickel) 157-073P-ST



MODEL 157-073P

### NOMINAL DIMENSIONS

MODEL	REACH	SPOUT HEIGHT	FAUCET HEIGHT
157-073P	9-3/4	6-1/4	9-3/4

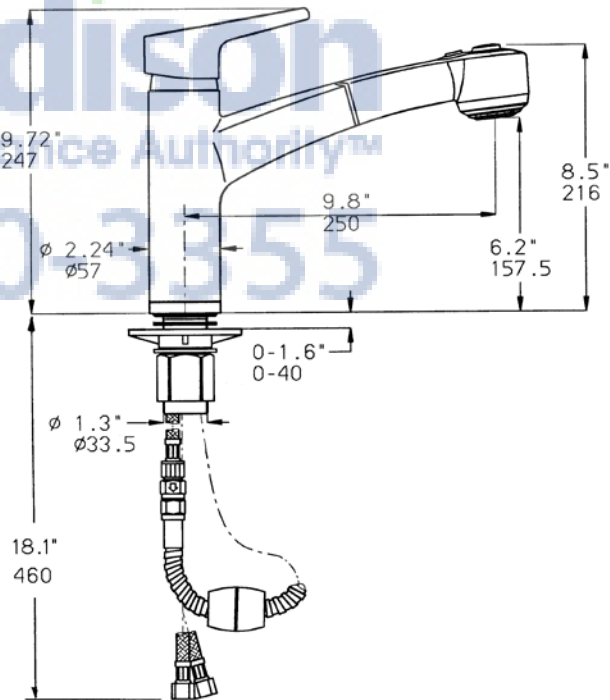

See next page for exploded parts drawing and parts list.

### JOB INFORMATION

Job Name: \_\_\_\_\_

Contact: \_\_\_\_\_

Date Specified: \_\_\_\_\_

Specifier: \_\_\_\_\_

Contractor: \_\_\_\_\_

**BLANCO AMERICA**  
**800.451.5782**  
**www.blancoamerica.com**

### BLANCOMERKUR PLUS™

### MODEL 157-073P

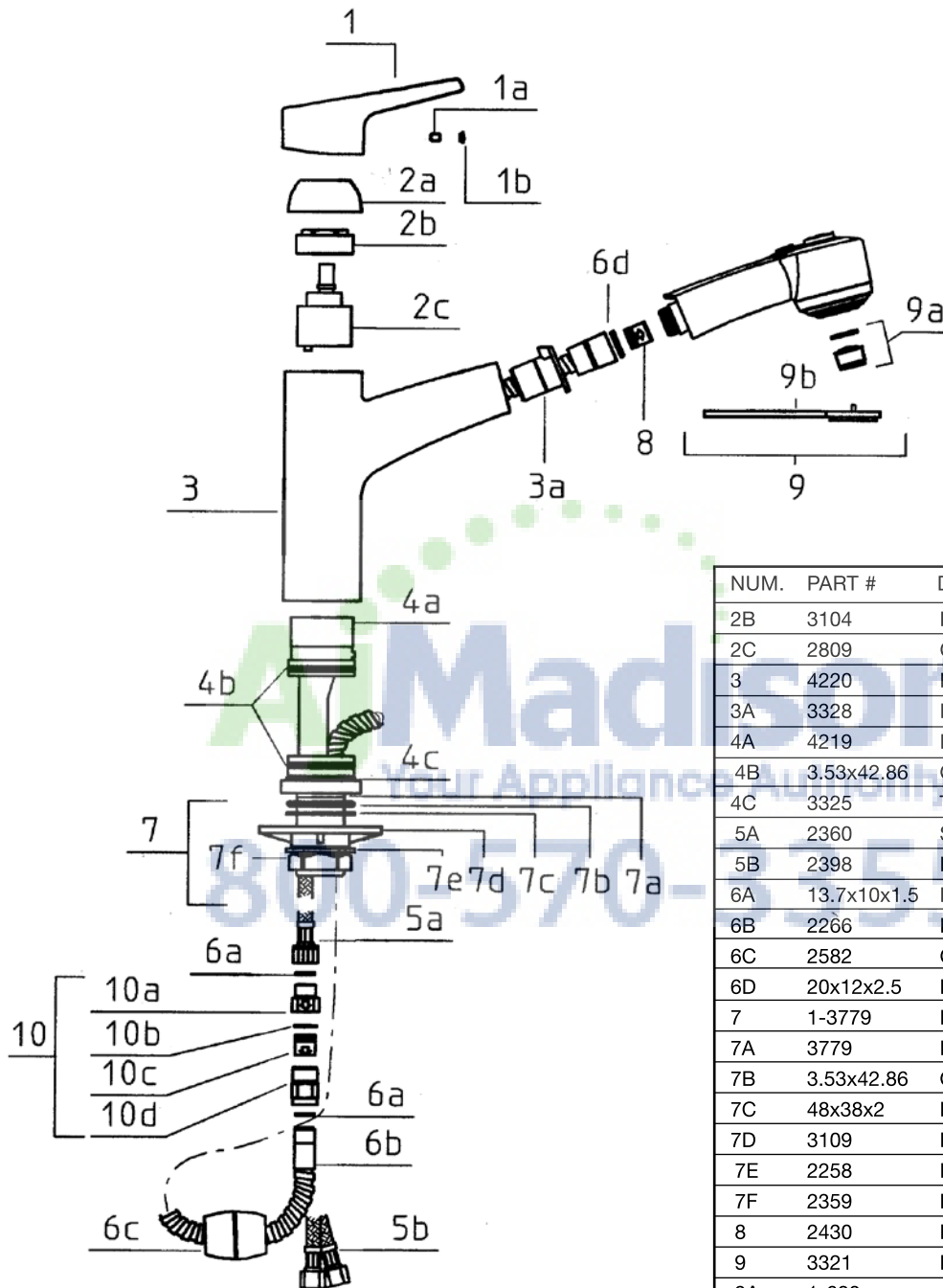

NUM.	PART #	DESCRIPTION
2B	3104	NUT
2C	2809	CARTRIDGE
3	4220	BODY
3A	3328	INSERT
4A	4219	INNER BODY
4B	3.53x42.86	O'RING
4C	3325	TEFLON BASE
5A	2360	SUPPLY TUBE
5B	2398	HOSE
6A	13.7x10x1.5	FIBER WASHER
6B	2266	HOSE
6C	2582	COUNTER WEIGHT
6D	20x12x2.5	RUBBER WASHER
7	1-3779	MOUNTING NUT ASSY
7A	3779	MOUNTING SLEEVE
7B	3.53x42.86	O'RING
7C	48x38x2	RUBBER WASHER
7D	3109	PLASTIC BASE
7E	2258	METAL WASHER
7F	2359	NUT
8	2430	FLOW RESTRICTOR/CHECK VALVE
9	3321	PULL OUT SPRAY
9A	1-680	AERATOR SET
9B	3347	KEY
10	1-3115	CHECK VALVE ASSY
10A	3116	NIPPLE
10B	16.5x12x1.5	FIBER WASHER
10C	2419	CHECK VALVE
10D	3115	CHECK VALVE BODY

NUM.	PART #	DESCRIPTION
1	4223	LEVER
1A	2058	SCREW
1B	1270	BUTTON
2A	3126	CAP