



CHROME  
01038351



BRUSHED CHROME  
01038352



MATTE BLACK  
01038353



ROSE GOLD  
01038354



BRUSHED GOLD  
01038355



NICKEL  
01038356



BRUSHED NICKEL  
01038357

# HYDROTAP® CUBE FOR HOME

**BOILING** | **CHILLED** | **SPARKLING**

The stylish HydroTap Cube BCS will complement every lifestyle, with on demand sparkling, boiling and chilled water. Unbottle the future. Choose sustainable hydration with HydroTap by Zip Water - the world's most advanced drinking water system.

# HYDROTAP® CUBE FOR HOME

**BOILING** | **CHILLED** | **SPARKLING**



## TAP SPECS

Style	HydroTap Cube-includes child safety lock
Hole Size	1 3/8"
Available Finishes	Chrome, Brushed Chrome, Matte Black, Rose Gold, Brushed Gold, Nickel & Brushed Nickel
Installation	Over Sink or On Drip Tray (Optional Font - see accessories)
Flow rate	Max 1.8gpm
Sparkling Water Flow Rate	0.36 gpm

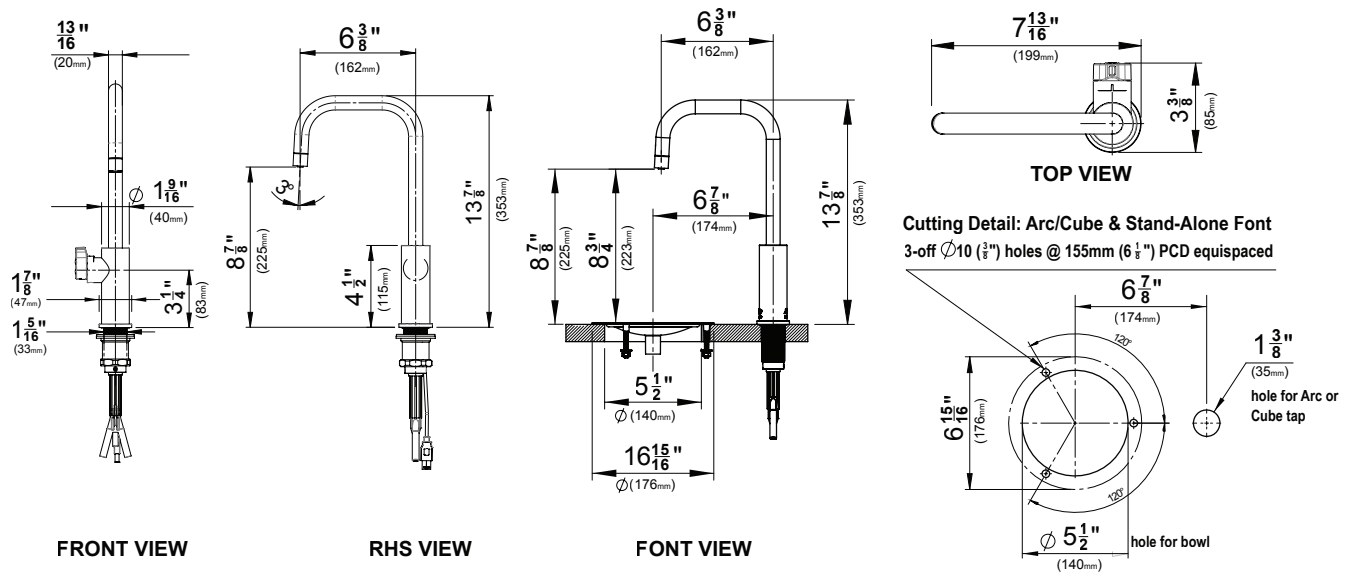

### ORDER CODES FOR PRODUCTS

01038351	BCS100/75 - Cube (Chrome)
01038352	BCS100/75 - Cube (Brushed Chrome)
01038353	BCS100/75 - Cube (Matte Black)
01038354	BCS100/75 - Cube (Rose Gold)
01038355	BCS100/75 - Cube (Brushed Gold)
01038356	BCS100/75 - Cube (Nickel)
01038357	BCS100/75 - Cube (Brushed Nickel)

### ORDER CODES FOR OPTIONAL FONTS

01034269	Drip Tray, Design Range Font (Chrome)
01034270	Drip Tray, Design Range Font (Brushed Chrome)
01034271	Drip Tray, Design Range Font (Matte Black)
01034272	Drip Tray, Design Range Font (Rose Gold)
01034273	Drip Tray, Design Range Font (Brushed Gold)
01034274	Drip Tray, Design Range Font (Nickel)
01034275	Drip Tray, Design Range Font (Brushed Nickel)

### ORDER CODES FOR SCALE FILTER KITS

01037874	Zip Scale Filter Installation Kit G4 2250 Liter [595gal] - FL250G4
01037875	Zip Scale Filter Installation Kit G4 3750 Liter [990gal] - FL500G4
01037876	Zip Scale Filter Installation Kit G4 7000 Liter [1850gal] - FL1000G4
01037877	Zip Scale Filter Installation Kit G4 10000 Liter [2640gal] - FL1500G4

### ORDER CODES FOR REPLACEMENT FILTERS

01034276	Filter, Zip, 0.2 Micron, 1 Size - 93701
01034278	Filter, Zip, 3 Micron, 1.5 Size - 93703

### ORDER CODES FOR REPLACEMENT CO<sub>2</sub>

01034347	Zip 2 x 1.5lb CO <sub>2</sub> refillable/recyclable cylinders
01034349	Zip CO <sub>2</sub> Regulator

# HYDROTAP® CUBE FOR HOME

**BOILING | CHILLED | SPARKLING**



## COMMAND CENTER SPECS

Water Pressure	Min 30psi – Max 75psi with a minimum flow rate of 1 gpm
Water Connection	½" BSP - isolation valve is required within 3' of the installation
Integral Water Values	HydroTaps are fitted with a Dual Check Valve and a 50psi Pressure Limiting Valve
Water Supply Requirements	Potable drinking water supply
Total Dissolved Solids (TDS)	TDS Min 50ppm – Max 120ppm
Integral Water Filter	0.2 micron, 1 size - Replace every 1,500 gallons or 12 months
Power Rating	110-120V, 60 Hz, 1.25kW
Power Supply Requirements	110-120V, 60Hz 15 amp power supply with a NEMA 5-15 outlet
Dimensions (WxDxH)	13.4" x 18.2" x 13.1"
Minimum Air Gap	Clearances are required - 2" Left side , 2" Right side , 8" Above
Dry Weight	85lbs
Product Approvals	WQA - NSF/ANSI 372, 42 & 53, cUL, CEC
Warranty	2 years (1 year Limited Warranty plus additional 1 year Warranty is available on product registration)
CO <sub>2</sub> Cylinder	2 x 1.5lb Beverage Grade Carbon Dioxide Cylinder
CO <sub>2</sub> Operating Pressure	Approximately 950 8oz cups
CO <sub>2</sub> Cylinder	Min 39psi - Max 43psi

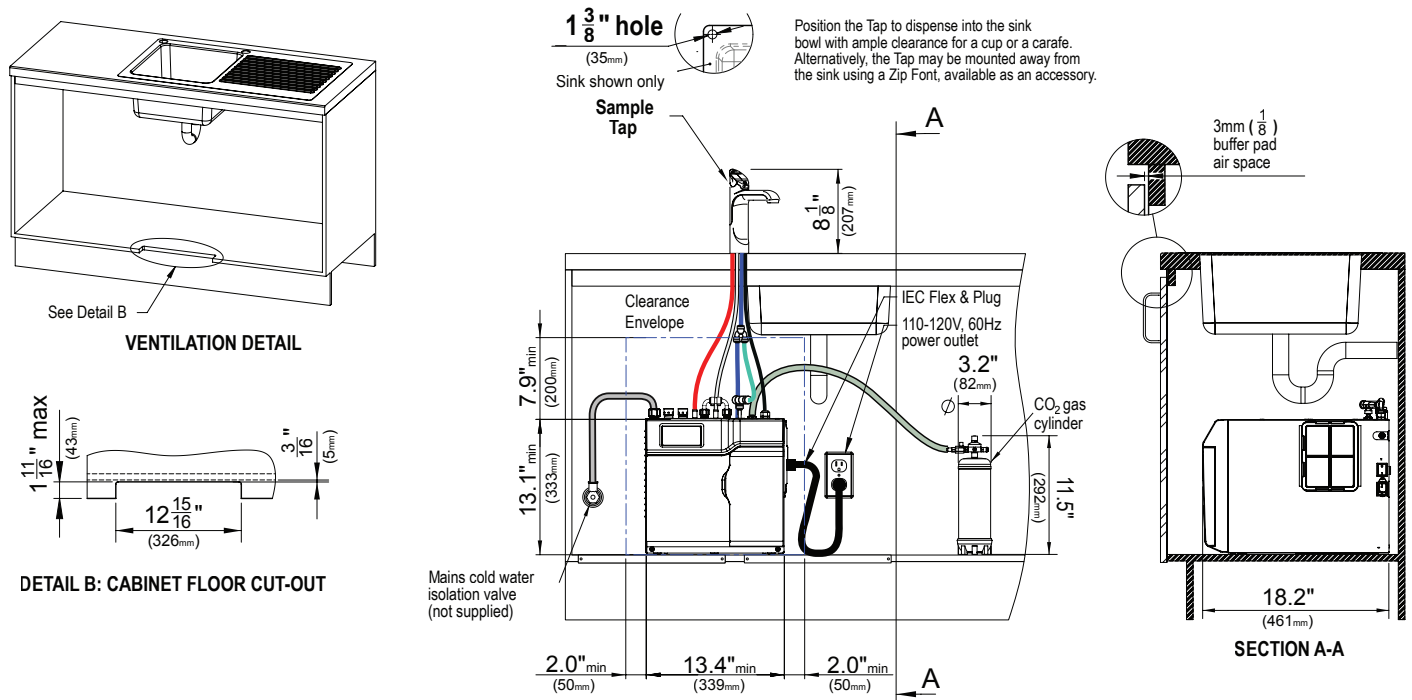

Installation and connection of your HydroTap must be carried out by a qualified person, observing all local, state, & federal regulations. You will require suitable 110 -120V 60Hz 15 amp power supply with a NEMA 5-15 electrical outlet within 3' of the product. The HydroTap is an air-cooled system, so discrete cabinetry cut-outs are required for ventilation. Installation on most counter tops is straightforward, however some stone counter tops may require a specialized cutting service. If using a drip tray (font) accessory, suitable drainage to a trapped waste is required within 3' of the installation. If you live in an area with hard water (more than 120ppm), we recommend installation of a scale filtration kit. Sufficient space and clearance to install the HydroTap as detailed in the product installation guidelines is required. Installation by Zip Professional Service can be arranged with a phone call to 1-833-233-2358 or through [www.us.zipwater.com](http://www.us.zipwater.com)