

Dart Canyon Stainless Steel Farmhouse Sink Installation Instructions



ATTENTION INSTALLER: Carefully read these instructions before you begin.



WARNING: Always wear safety goggles and gloves when installing the sink to prevent personal injury.

- ***Recommend that undermount sinks should be installed by a professional or experienced installer.***
- **WARNING:** Due to the custom nature of this type of installation, no cutout template is included. Recommend providing the cabinet maker/installer with the actual sink to be installed prior to cabinet fabrication. It is further recommended that the installer(s) discuss this with the customer and agree that the finished appearance is the desired effect. Not responsible for improper sink or countertop installations.
- Proper installation requires a coordinated effort including advanced dialog between the designer (or customer), the cabinet maker, the countertop fabricator and the sink installer during the design and installation phase.
- Not responsible for sink or countertop if damaged during installation.
- Metal edges may be sharp, use caution when handling.
- Inspect sink for damage prior to beginning installation.
- Follow all local plumbing and building codes.

For non-ADA installation with sink base cabinet: a standard sink base cabinet will need to be modified for a farmhouse apron sink. Due to the height of the ADA-styled apron, there will be a noticeable 1” (or greater) gap in height spanning the width of the sink just beneath the sinks apron. A wood finish-matching cabinet filler is recommended to fill this area.

- When sink and cabinet are correctly matched the sink can rest on side walls of cabinet and not require side clips. Material may be required to be removed from cabinet to level sink beneath counter. For non-ADA installation method, installer is responsible for choosing the proper cabinet type (strong) to support the sink.

Standard Sink Base Cabinet Installation Profile (non-ADA)

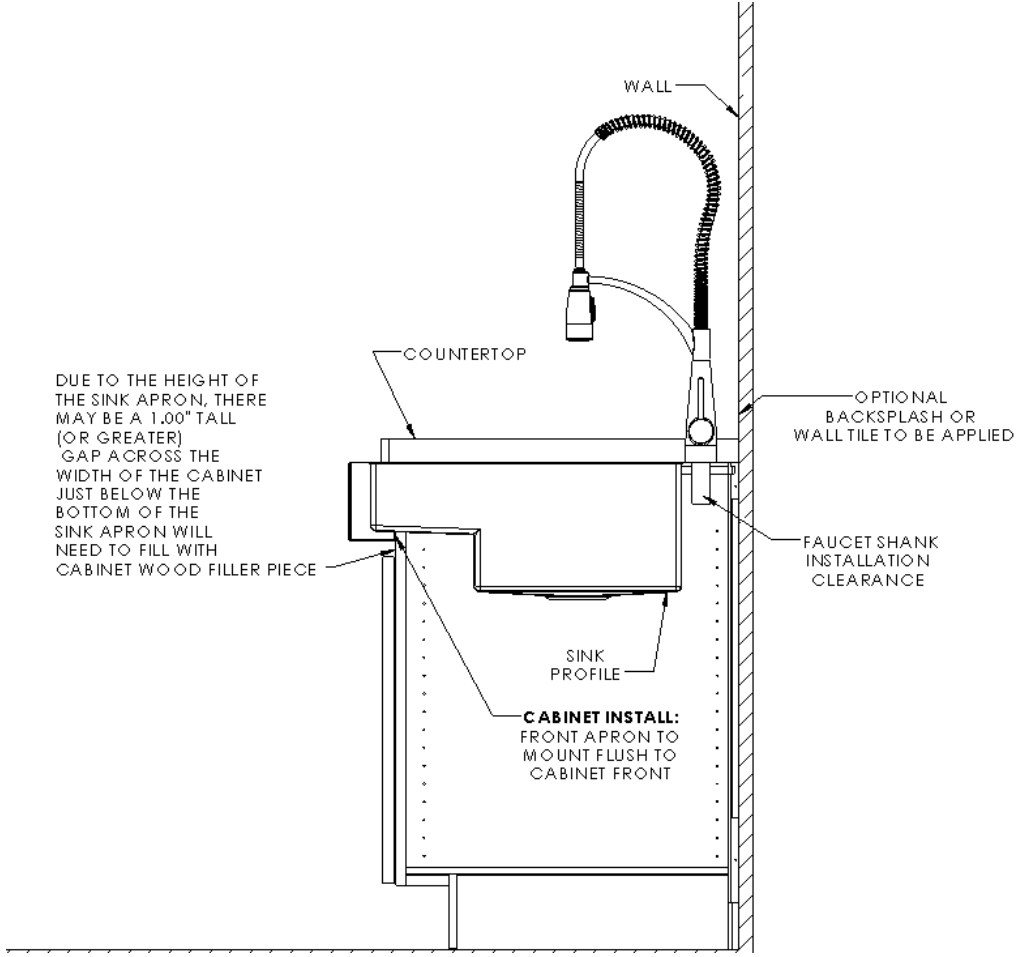

Figure 1.

- **For ADA installation method: Follow 2010 ADA STANDARDS for Accessible Design for Proper Knee Clearance (Sec. 306.3 – Knee Clearance)**
- **For ADA installation method:** Sink will need to be supported with a custom support frame that is braced between two cabinets. The custom support frame will need to be constructed and placed at proper height according to ADA guidelines. See **Figure 3** for example. Sink must be installed at a maximum finished working height of 34” measuring from floor to top of sink surface. In addition, there will need to be a minimum of 27” of knee clearance under sink. Custom countertop build-up may be necessary near recessed sink transition.
- For ADA installation method, installer will need to ensure that the neighboring cabinets are strong enough to support the sink and frame support bracing.
- For ADA installation method, under-sink front covers/panels will not be provided. This is a custom option provided by installer/fabricator.

ADA Installation Profile

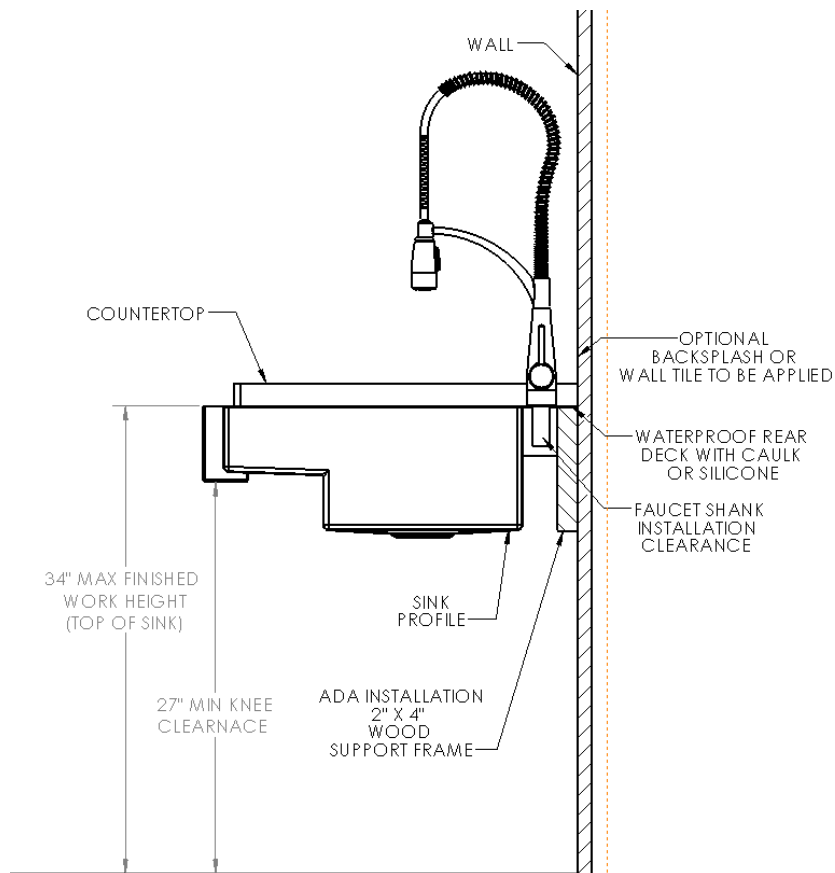

Figure 2.

ADA Knee Clearance Guideline

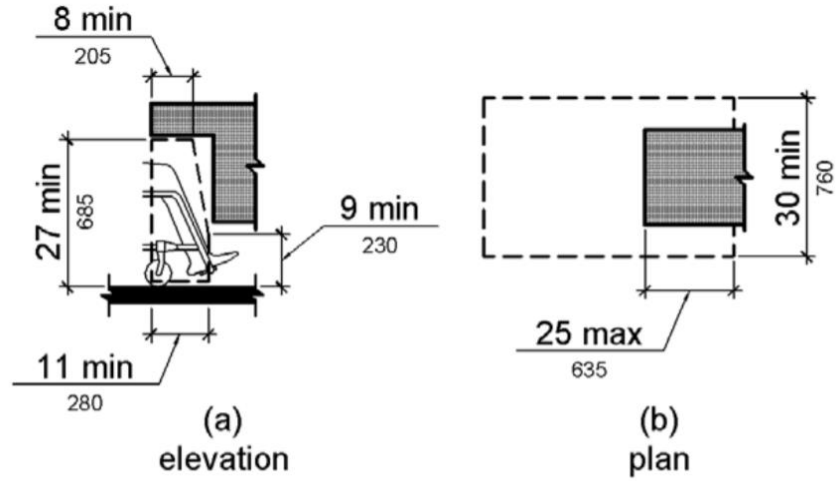

Figure 306.3
Knee Clearance

ADA Site: https://www.ada.gov/regs2010/2010ADAStandards/2010ADAStandards_prt.pdf

Figure 3.

SUPPORT FRAME FOR ADA INSTALLATION

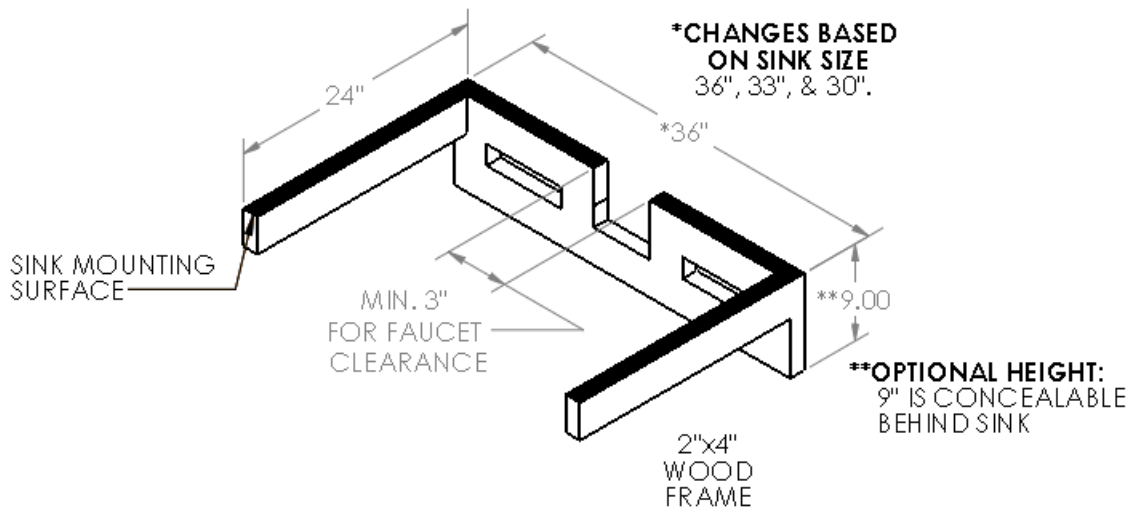

Figure 4.

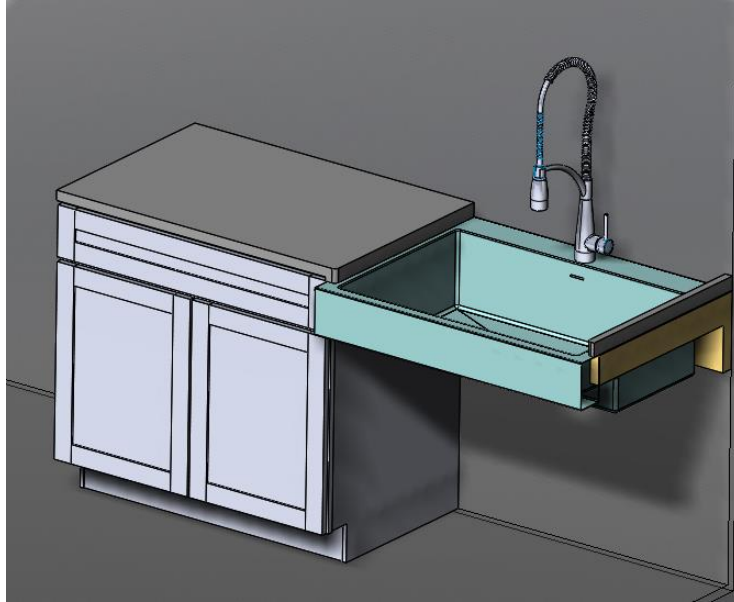

Figure 5.

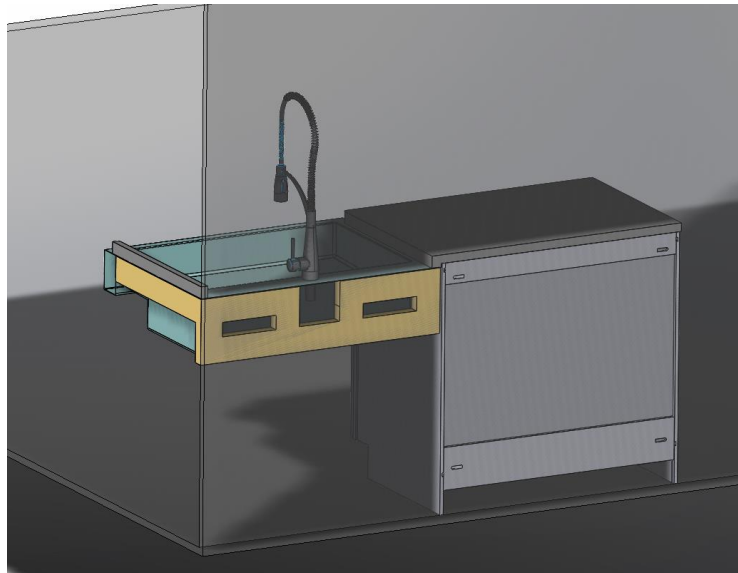

Figure 6.