

PRO366BCFEPCAT

PROFESSIONAL SERIES DUAL-FUEL RANGE 36" - 6 BRASS BURNERS +
CAST-IRON GRIDDLE - SELF-CLEAN OVEN - CARBONIO FINISH



Exclusive Finish and Materials

Italian style and craftsmanship inspire the exclusive Carbonio finish of this range. Titanium knobs and handles make the range a standout in every kitchen. Carbonio finish toe-kick included with the range.

Bertazzoni signature counter-deep maintop

Bertazzoni signature stainless counter-deep maintop is designed to install flush with most kitchen countertops for a perfectly integrated look. Precise and flexible heating is generated through 6 Mono-bloc brass burners. 2 x 19000 BTUs power burners with dual ring of flame boil water in 6 minutes flat. A large, removable cast-iron griddle is included.

Extra large oven with dual convection

The 5.7 cu.ft electric self-clean oven with dual diagonal convection allows even baking and roasting on 7 shelf levels. Bertazzoni ovens are equipped with an extra-large high-power broiler for broiling and grilling.

Advanced programming and controls for the oven

The elegant digital gauge gives precise control of oven temperature during pre-heating, roasting and baking, and has integrated controls for the food temperature probe. This range comes with a dedicated air-frying mode for healthier cooking, to be used with the included stainless steel mesh basket.

Best-in-class features and design

The soft-close oven door with edge-to-edge tempered glass is a masterpiece of European engineering and makes the oven door very easy to wipe clean. Convenient smooth-glide telescopic racks on 2 levels help loading and unloading the oven.

GENERAL CHARACTERISTICS

Worktop	6 gas burners with 2 lateral dual wok
Burners	Brass burners
Pan support	Cast iron
Upstand/Lid cover	1" stainless steel island trim
Knobs	Metal finish with ergonomic shape
Cooking modes	10
Tray	1 baking tray w/grill trivet + 1 air fry basket
Shelves	2 heavy duty
Levels	Laterals grids
Telescopic guides	2 sliding guides
Inner door	Squared 3 glasses
Door hinges	Soft closing
Legs	Stainless Steel ø 2 3/8 inches

TECHNICAL SPECIFICATIONS

Electrical requirements	120/208 V 60HZ - 4500W 120/240 V 60HZ - 5900W 30A
Warranty	2 years parts & labor
Packaging dimensions	H:42 1/8 W:40 9/16 D:29 15/16

PRO366BCFEPCAT

PROFESSIONAL SERIES DUAL-FUEL RANGE 36" - 6 BRASS BURNERS + CAST-IRON GRIDDLE - SELF-CLEAN OVEN - CARBONIO FINISH



DIMENSIONS

SIDE VIEW

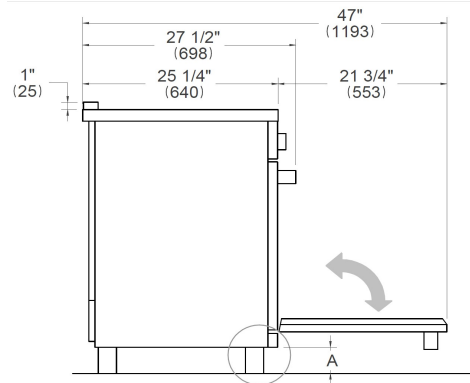

LEG DETAILS

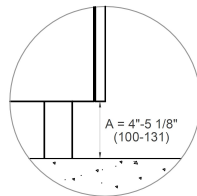

FRONT VIEW

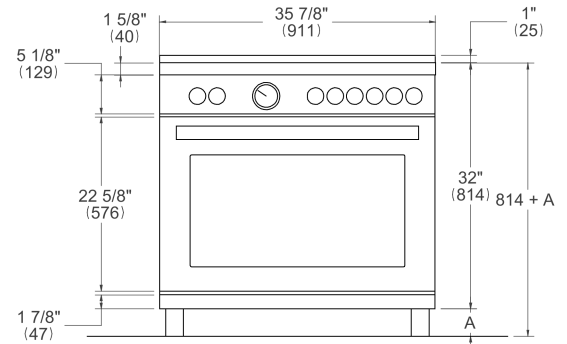

WORKTOP DETAILS

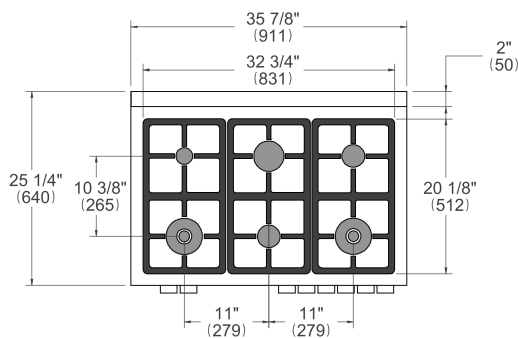

REAR VIEW

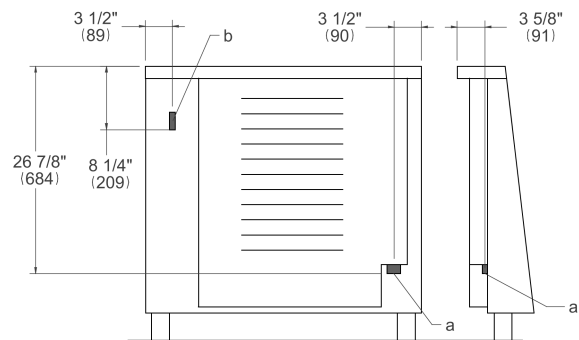

INSTALLATION

E A properly-grounded horizontally mounted electrical receptacle should be installed no higher than 3" (7.6 cm) above the floor, no less than 2" (5 cm) and no more than 8" (20,3 cm) from the left side (facing product). Check all local code requirements.

G Install agency approved, properly sized manual shut-off valve at max. height of 3" from floor, 2" min. height/ 8" max. height from the right side (facing product). Use approved shut-off valve & regulator gas connection, properly sized flex or rigid pipe. Check all local code requirements.

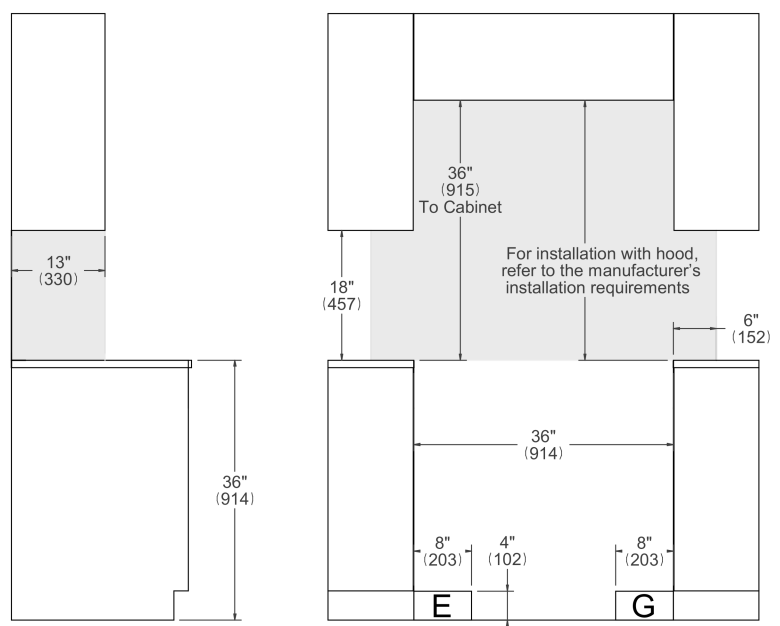

NOTE

a. Electrical Connection
b. Gas Connection

Disclaimer: while every effort has been made to insure the accuracy of the information contained in this document, Fratelli Bertazzoni reserves the right to change any part of the information at any time without notice. For detailed installation specifications consult the installation manual. Fratelli Bertazzoni, Bertazzoni and the winged wheel brand icon are registered trademarks of Bertazzoni Spa.