

Refrigerator Surround Kit

For Models E388, E450, E402B, E411T, E415H, E440T, E442B, E521T and E522B, RF610A, RF540A, RF201A



Kit Application

This kit is designed to be used with 1695mm to 1780mm (66 3/4" to 70 1/8") High cabinet models, incorporating the "B" series onwards refrigerators with curved & flat door styling.

Note: This kit can be used for combining any of the following products, E388, E450, E402B, E411T, E415H, E440T, E442B, E521T, E522B, RF610A, RF540A, RF201A

(Part number for each installation type on page 4)

To give the most integrated look, the kitchen cabinetry should be flush with the front of the refrigerator door.

Tools Required

- No. 2 square type drill bit - long
- Electric drill
- Flat blade screwdriver
- 1 x 16mm (11/16in) piece of MDF the same size as the base of the cavity.
- Joiner kit (part number 813690) required if joining two refrigerators side by side.



Parts Included in Kit

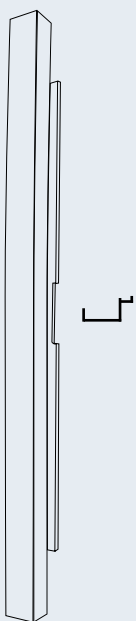

Top Trim (1)

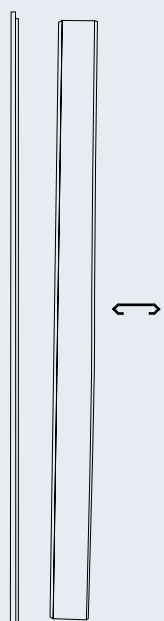

Side Trim (2)



Bottom Trim (1)

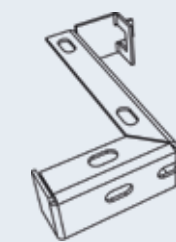

Top Trim Brackets
(2) Single Refrigerator Kits
(3) Two Refrigerator Kits

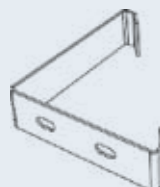

Side Trim Brackets (10)

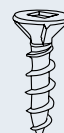

Screw Type A:
#8x12 Square Drive CSK (26)

Installation Procedure

Step 1

- 1 Check that the internal Cupboard Cavity dimensions are correct (see diagram 1).
- 2 Unpack the refrigerator and/or freezer cabinets from their separate delivery cartons (see individual cartons for unpacking procedures).
- 3 Ensure the floor and/or the cupboards are protected from damage during the unpacking and assembly of the cabinets.
- 4 Check the refrigerator and freezer doors are hinged on the desired side.
- 5 Check that the kit is complete (refer to kit parts list on page 1).

Note 1: Due to the size of the refrigerator cabinets, it is essential that assembly of the kit be undertaken with a minimum of two able-bodied persons.

Note 2: It is important to include adequate venting to the top of the cabinet to ensure the efficient operation of the refrigerator.

Diagram 1: Cutout Dimensions (flush to edge of door)

All Dimensions are quoted in millimetres & inches

Width of models mm - inch	Width A	Depth B*	Height C	Air Vent D
790 model	962 - 37 7/8"	700 - 27 9/16"	1806 - 71 1/8"	200 - 8"
900 model	1072 - 42 1/4"	700 - 27 9/16"	1891 - 74 1/2"	200 - 8"
635 model + 635 model	1467 - 57 49/64"	700 - 27 9/16"	1806 - 71 1/8"	200 - 8"
680 model + 680 model	1557 - 61 19/64"	700 - 27 9/16"	1806 - 71 1/8"	200 - 8"
790 model + 790 model	1777 - 70"	700 - 27 9/16"	1806 - 71 1/8"	200 - 8"

* Depth is a minimum requirement

Cut out dimensions above are to be used as **minimum** dimensions.

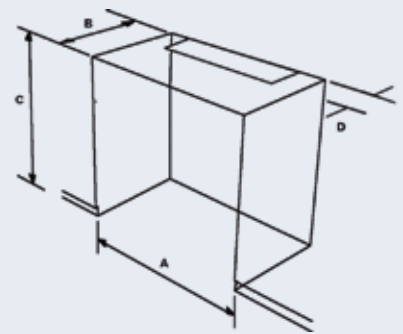

Step 2

- 1 Locate the two/three top trim brackets.
- 2 For two refrigerator kits, one bracket is to be screwed in the top centre of the cabinet, secure the top bracket with two of the screws (Type A, #8 x 12 SQ Drive CSK).
- 3 For all kits, the remaining two brackets are to be secured on either side, by two screws which are mounted from the side (see diagram 2).
- 4 Looking at the front of the product, place the top brackets on top of the cabinet.
- 5 Care must be taken to line up the top front edge of the brackets with the leading edge of the cabinet.

Diagram 2: Top Trim Brackets

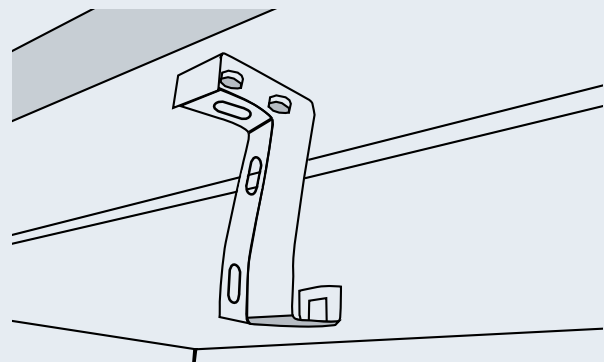
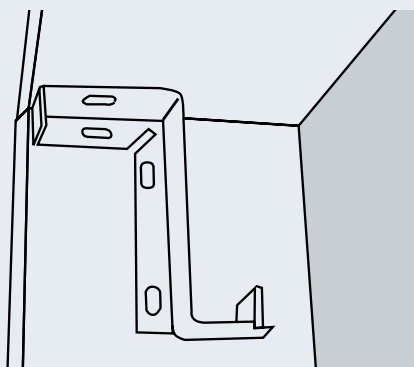

Step 3

- 1 Locate the ten side trim brackets.
- 2 Position five brackets to the left hand side of the cabinet's and the remaining five brackets to the right hand side of the cabinet's.
- 3 Brackets should be evenly spaced down each side (see diagram 3). Secure each of these brackets with the two screws provided.
- 4 Care must be taken to line up the front edge of the brackets with the leading edges of the cabinet.

Diagram 3: Side Trim Brackets

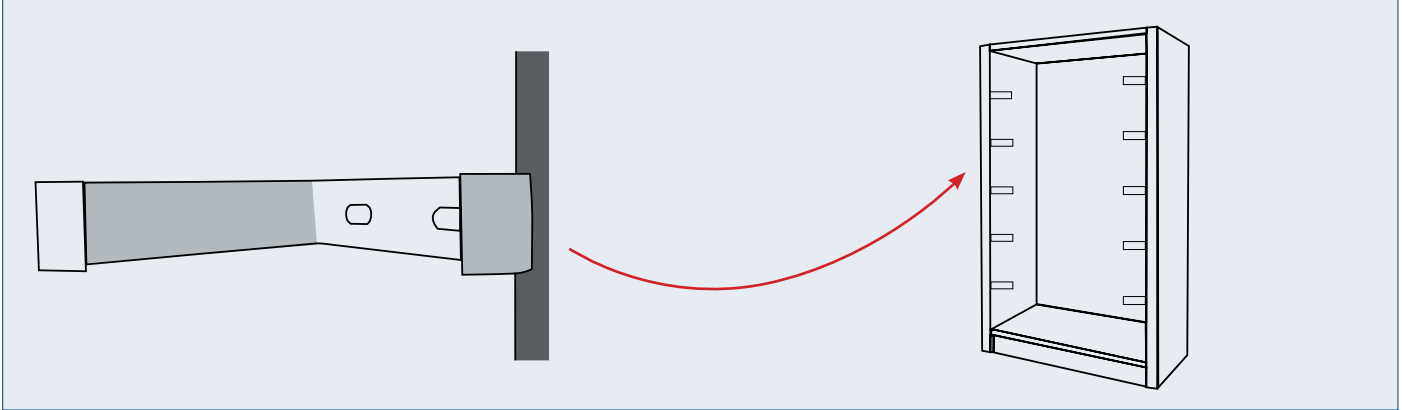

Step 4

Place 16mm (11/16in) piece of MDF the same size as the base of the cavity into cavity. See diagram 4.

Diagram 4: MDF Board

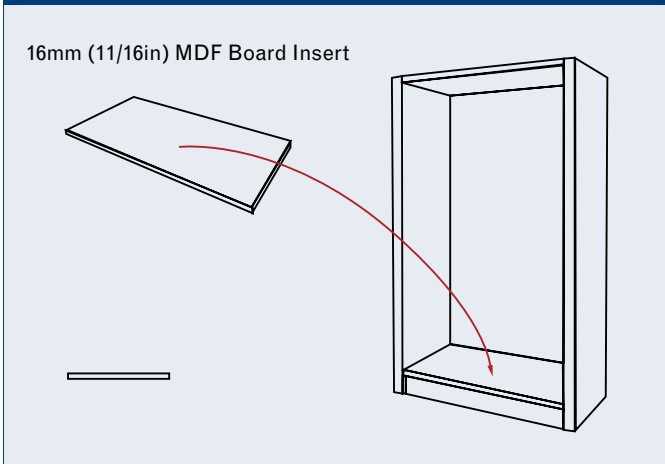
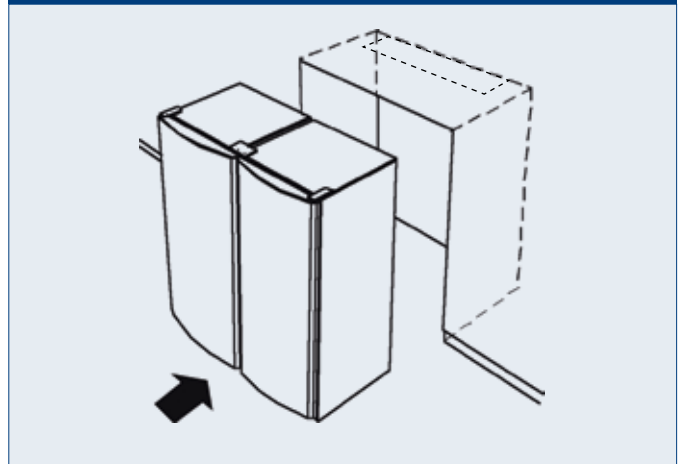

Diagram 5: Trim Installation



Step 5

- 1 Remove protective coating film from surround trim.
- 2 To install the surrounds, first clip in top surround.
- 3 Ensure the locator strips at the rear of the top brackets clip into the rear of the top trim, then clip both side trims into place starting from the front cabinet edge.
- 4 Lastly install the bottom trim. The bottom trim requires an 16mm (11/16in) piece of MDF the same size as the base of the cavity to sit on. See diagram 4.

Step 6

- 1 If installing two refrigerators/freezers side by side a joiner kit is required (part number 813690). Refer to these instructions and fit joiner kit before pushing refrigerator into place, see diagram 5.
- 2 Plug refrigerator into electrical socket, run water connection to refrigerator if required (Ice & Water models only).
- 3 Gently install refrigerator into cabinetry making sure it is centred within the surround trim.

The front of the refrigerator door should be flush with the front of the cabinetry to obtain an integrated look.

Kit Part Numbers and Cut Out Dimensions Table							
Refrigerator Model Width		Part Numbers			Cut Out Dimensions		
		Brushed Stainless	Iridium Stainless	Plus Joiner Kit	Width A	Depth B*	Height C
1 x 790 LH		818 758	814 678		962mm 37" 7/8	700mm 27" 9/16	1806mm 71" 1/8
2 x 790		818 759	814 679	813690	1777mm 70"	700mm 27" 9/16	1806mm 71" 1/8
2 x 680		818 760	814 680	813690	1557mm 61" 19/64	700mm 27" 9/16	1806mm 71" 1/8
2 x 635		818 761	814 681	813690	1467mm 57" 49/64	700mm 27" 9/16	1806mm 71" 1/8
1 x 790 RH		818 762	814 682		962mm 37" 7/8	700mm 27" 9/16	1806mm 71" 1/8
1 x 900		818 763	814 683		1072mm 42" 1/4	700mm 27" 9/16	1891mm 74" 1/2

* Depth is a minimum requirement

Part Number: 819150
June 2007

