

ASPIRE
BY HESTAN



24" REFRIGERATOR

- 304 stainless steel exterior
- 32-7/8" H x 23-5/8" W x 23-1/2" D
- Commercial Marquis™ handle and commercial grade end caps
- 5.6 cu. ft. of total storage capacity
- Door lock
- LED interior lighting
- Field reversible door
- 3 Heavy-duty chrome plated adjustable shelves
- 36° - 64° F temperature range
- Digital temperature display
- Stainless steel toe-kick
- 96 lb. net weight
- Automatic defrost
- Built-in or freestanding application
- Front vented, forced air refrigeration system
- Adjustable leveling legs
- ETL (CETL) certified for outdoor use
- R134a Refrigerant



24" DROP-IN COOLER

- 304 stainless steel interior and exterior
- Cooler dimensions:
25-3/8" L x 25-3/8" W x 16" D
- Cutout dimensions:
23-11/16" L x 23-11/16" W x 16-1/4" D
- Extra-deep, accommodates wine bottles standing up
- 1" R-Tech high-performance insulated walls
- Includes 5 individual condiment trays
- Convenient drain with 1/2" NPS connection and rubber stopper
- Heavy-duty lid hinges
- Lid prop holds lid in fully open position
- Convenient handle for ease of use
- Lifetime warranty

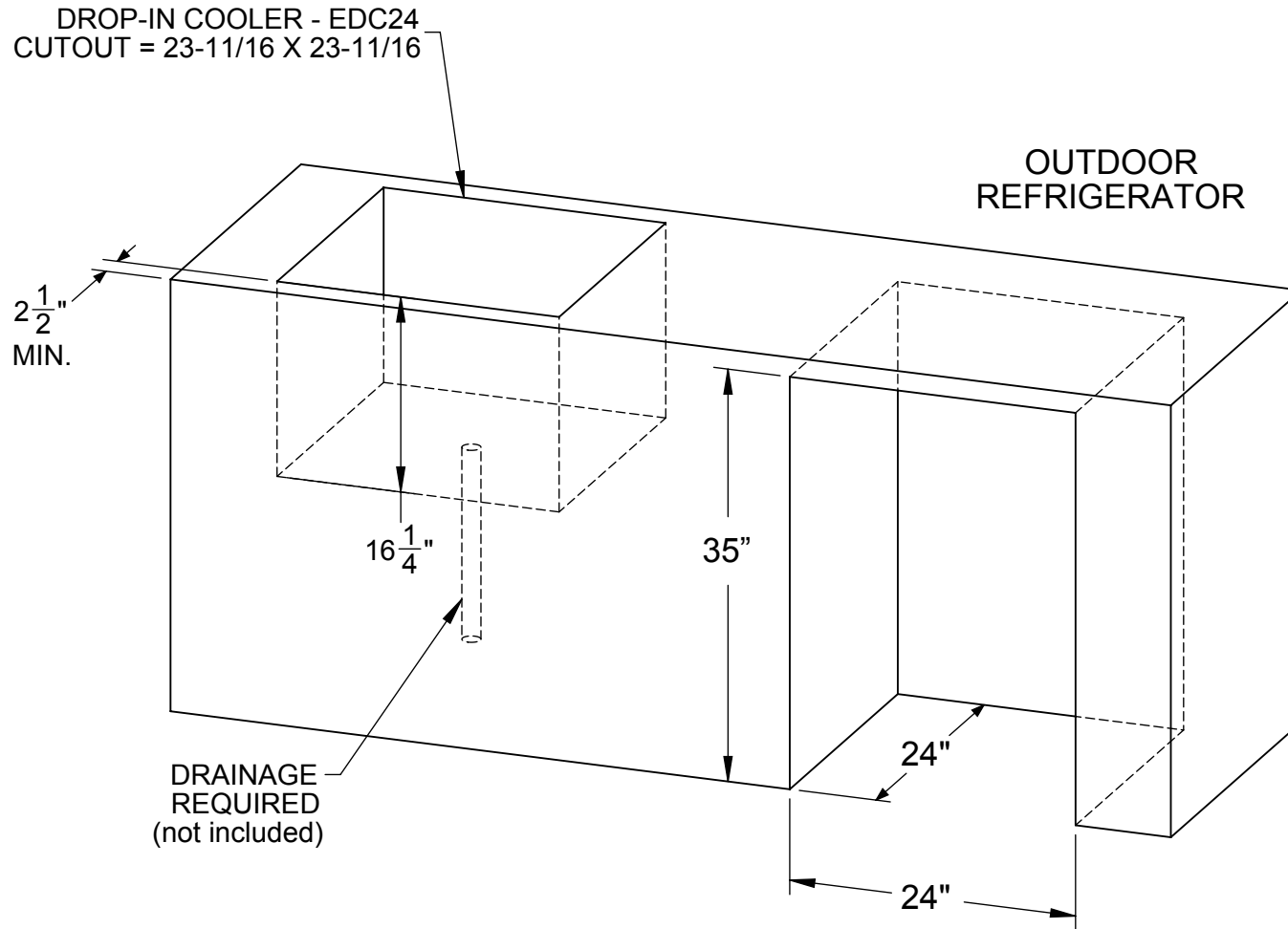

Models	Description	Electrical Requirements
ERS24	24" Outdoor Refrigerator, Solid Door with Lock	115V, 60Hz., 1 Phase, 2.2 amps
EDC24	24" Outdoor Drop-In Cooler	n/a

Aspire by Hestan products are approved for outdoor use only. Hestan Commercial Corporation reserves the right to change materials and specifications without notice.

